

HELPMAN

Air cooled Condensers

HTC

New condenser generation with better performance

Capacities 9 - 1060 kW



Ripple Fin® tubing

Floating coil block suspension

Eurovent certified

**Capacities based on
ENV 327 voor R404A**

EUROVENT
CERTIFIED PERFORMANCE



CERTIFY-ALL

*DX Air Coolers
Air Cooled Condensers
Dry Coolers

Air Cooled Condensers

HTC

Contents

Page

3	General information
4 - 11	Nominal duty air flow, sound levels technical data, dimensions
12	Fan types Fan motors
13	Capacity calculation Correction factors
14	Extended feet Additional information

Certified by Eurovent

HTC aircooled condensers are tested and certified by Eurovent according to ENV 327 European standard.

This extensive testing procedure comprises :

- capacities under standardised conditions
- air flow data
- sound levels
- fan capacities

Type indication

Example : **HTC 076 . 124 - 930**

- HTC** : Aircooled condenser with Cu/Al coil block
- 076** : Condenser type
There are 5 basic types with different fan diameters
- 1••** : Number of separated coils
- 2•** : Number of fans per coil
- 4** : Number of tube rows in air direction
- 930** : Fan speed

Air Cooled Condensers

HTC



General

The HTC aircooled condenser range includes 5 basic types covering a total of 137 models with 1 to 12 fans and duties from 9 to 1060 kW at 15 K temperature difference.

Design

Coil block	: Copper Ripple Fin® tubing with aluminium fins.
Tube diameter	: 1/2"
Tube thickness	: 0.65 mm/0.4 mm (min.)
Tube pitch	: 50 x 50 mm triangle
Fin spacing	: 2.25 mm

Other fin spacings up to 4 mm available on request.

Coil blocks are pressure tested at 28 bar dry air.

Casing and framework are of pregalvanised sheet steel (Sendzimir) with an epoxy coating on both sides. Colour scheme: light-grey RAL 7035, mounting feet models 076, 090, 091 and 100, dark-grey RAL 7016. Other colours are available at an extra price. All condensers are provided with removable header panels.

Floating construction of the condenser coil block. On request the condensers can be fitted with inspection hatches (extra price).

Air direction

Condensers type HTC can be supplied for horizontal or vertical air flow.

Condenser models 050 :

Standard horizontal air flow, vertical air flow with special refrigerant circuiting. All models are fitted with mounting profiles.

Condenser models 076, 090, 091 and 100 :

Standard vertical air flow. On request also available for horizontal air flow.

When ordering without air flow indication, the standard execution will be supplied.

Corrosion protection

The standard condensers have a high corrosion resistance through selected materials, surface treatment and construction. For application in aggressive surroundings (coastal-and industrial areas) following designs are available at an extra charge:

- fins of seawater resistant aluminium alloy (57S/5052)
- fins of prepainted aluminium
- finned coil coated after assembling

Application as liquid cooler (Dry - Cooler)

The condenser can also be used as liquid cooler, for instance cooling down of cooling water in watercooled plants.

Technical information on request, see brochure nr. 53.08 (Dry Coolers HTD).

Air Cooled Condensers

HTC

Capacities HTC 1**

Type HTC	Capacity kW		Airflow m ³ /h		dB(A) H/L	Capacity kW		Airflow m ³ /h		dB(A) H/L	Capacity kW		Airflow m ³ /h		dB(A) H/L
	H	L	H	L		H	L	H	L		H	L	H	L	
HTC 090	n = 850 / 610 rpm					n = 680 / 520 rpm					n = 860 / 660 rpm				
090 . 112 - ...	58.7	50.6	30700	22700	56/49	51.5	47.1	23400	17200	51/45	49.5	46.6	21700	16900	53/47
090 . 113 - ...	78.3	69.3	28500	21100	56/49	69.8	58.4	21400	15900	51/45	68.5	57.7	20700	15500	53/47
090 . 114 - ...	88.5	79.1	26600	19800	56/49	78.8	65.2	19800	14800	51/45	78.8	64.0	19800	14400	53/47
090 . 122 - ...	117.9	110.0	61500	45400	59/52	111.9	95.2	46900	34400	54/48	107.4	94.1	43300	33700	56/50
090 . 123 - ...	165.6	140.0	57000	42200	59/52	141.0	118.0	42800	31800	54/48	138.3	116.1	41400	31000	56/50
090 . 124 - ...	191.4	159.1	53300	39600	59/52	158.6	134.2	39500	29600	54/48	158.6	131.7	39500	28900	56/50
090 . 132 - ...	182.9	166.0	92200	68000	61/54	168.7	143.3	70300	51600	56/50	162.0	141.6	65000	50600	58/52
090 . 133 - ...	249.7	210.5	85400	63300	61/54	212.2	177.1	64100	47800	56/50	208.0	174.5	62100	46600	58/52
090 . 134 - ...	288.4	238.5	79900	59500	61/54	238.7	203.9	59300	44400	56/50	238.7	199.8	59300	43300	58/52
090 . 142 - ...	257.9	221.8	122900	90700	62/55	225.7	191.4	93800	68800	57/51	216.5	189.1	86600	67400	59/53
090 . 143 - ...	333.6	281.3	113900	84500	62/55	283.5	244.3	85500	63700	57/51	278.0	240.2	82800	62100	59/53
090 . 144 - ...	385.4	329.0	106500	79300	62/55	328.6	270.0	79000	59200	57/51	328.6	265.5	79000	57700	59/53
090 . 152 - ...	313.0	268.7	153700	113400	63/56	273.5	245.8	117200	86000	58/52	262.4	243.0	108300	84300	60/54
090 . 153 - ...	404.6	361.6	142400	105600	63/56	364.0	304.4	106900	79600	58/52	357.6	299.4	103500	77600	60/54
090 . 154 - ...	494.9	409.7	133200	99100	63/56	409.2	335.6	98800	74000	58/52	409.2	329.6	98800	72100	60/54
HTC 091	n = 850 / 610 rpm					n = 680 / 520 rpm					n = 860 / 660 rpm				
091 . 112 - ...	70.4	60.3	32200	23700	56/49	61.9	52.1	24900	18100	51/45	58.2	51.4	22300	17700	53/47
091 . 113 - ...	93.0	77.8	30300	22400	56/49	81.0	67.5	23800	17000	51/45	76.0	66.5	21500	16600	53/47
091 . 114 - ...	105.5	86.7	28700	21200	56/49	87.7	74.8	21600	16000	51/45	89.8	73.6	20800	15600	53/47
091 . 122 - ...	142.0	121.3	64300	47400	59/52	124.5	104.5	49800	36300	54/48	117.1	103.1	44500	35400	56/50
091 . 123 - ...	183.7	153.5	60600	44700	59/52	159.6	136.2	47700	33900	54/48	158.2	134.1	43000	33100	56/50
091 . 124 - ...	211.4	183.4	57400	42500	59/52	185.0	150.8	43100	32100	54/48	181.1	147.6	41600	31300	56/50
091 . 132 - ...	218.2	186.3	96500	71100	61/54	191.2	166.3	74700	54400	56/50	179.9	164.0	66800	53100	58/52
091 . 133 - ...	281.9	244.2	90800	67100	61/54	254.0	204.7	71500	50900	56/50	238.1	201.3	64400	49700	58/52
091 . 134 - ...	335.9	276.3	86100	63700	61/54	278.9	226.2	64700	48100	56/50	271.8	221.9	62400	46900	58/52
091 . 142 - ...	285.1	243.0	128600	94800	62/55	249.7	222.5	99600	72600	57/51	249.0	219.3	89000	70800	59/53
091 . 143 - ...	368.0	326.6	121100	89500	62/55	339.1	273.4	95400	67900	57/51	318.3	268.9	85900	66200	59/53
091 . 144 - ...	449.4	367.8	114700	85000	62/55	372.6	308.2	86300	64100	57/51	363.1	302.5	83200	62600	59/53
091 . 152 - ...	370.9	316.4	160800	118500	63/56	324.8	272.4	124500	90700	58/52	305.4	268.3	111300	88500	60/54
091 . 153 - ...	478.7	399.6	151400	111800	63/56	415.5	335.3	119200	84900	58/52	389.4	342.1	107400	82800	60/54
091 . 154 - ...	549.5	450.9	143400	106200	63/56	456.2	384.9	107800	80200	58/52	461.8	377.2	104000	78200	60/54
HTC 100	n = 670 / 520 rpm					n = 420 / 310 rpm					n = 380 / 250 rpm				
100 . 112 - ...	59.0	49.8	27400	19900	59/47	48.7	41.2	19000	13500	42/34	45.0	35.2	17000	10800	39/29
100 . 113 - ...	74.8	61.4	25100	18100	59/47	62.0	47.4	16700	11700	42/34	56.0	38.3	14500	9000	39/29
100 . 114 - ...	89.5	73.3	23300	16200	59/47	66.5	-	14300	-	42	59.0	-	13000	-	39
100 . 122 - ...	118.7	100.0	54700	39900	62/50	103.2	78.7	38000	27000	45/37	95.5	70.7	34000	21600	42/32
100 . 123 - ...	149.9	129.9	50100	36200	62/50	124.8	95.4	33400	23400	45/37	112.3	78.7	29000	18000	42/32
100 . 124 - ...	189.3	147.9	46500	32300	62/50	135.9	-	28600	-	45	120.8	-	26000	-	42
100 . 132 - ...	166.4	159.5	82100	59800	64/52	155.5	124.9	57000	40500	47/39	143.7	106.0	51000	32400	44/34
100 . 133 - ...	238.8	195.6	75200	54300	64/52	187.8	143.4	50100	35100	47/39	169.0	118.2	43500	27000	44/34
100 . 134 - ...	285.2	221.7	69800	48500	64/52	199.6	-	42900	-	47	176.8	-	39000	-	44
100 . 142 - ...	238.1	200.6	109500	79700	65/53	195.5	157.7	76000	54000	48/40	180.6	144.8	68000	43200	45/35
100 . 143 - ...	319.4	260.6	100200	72400	65/53	250.8	191.4	66800	46800	48/40	230.5	156.9	58000	36000	45/35
100 . 144 - ...	381.1	302.6	93100	64700	65/53	272.4	-	57200	-	48	241.3	-	52000	-	45
100 . 152 - ...	310.1	260.8	136900	99600	66/54	262.2	204.2	95000	67500	49/41	234.8	173.6	85000	54000	46/36
100 . 153 - ...	390.9	318.9	125300	90500	66/54	319.2	243.3	83500	58500	49/41	287.1	198.6	72500	45000	46/36
100 . 154 - ...	484.8	377.6	116300	80800	66/54	339.9	-	71500	-	49	305.0	-	65000	-	46

H = High fan speed

L = Low fan speed

Note : Actual fan speed may differ from the values as indicated on the motor name plate.

Air Cooled Condensers

HTC

Technical Data HTC 1..

Type HTC	Refrigerant conn. mm	Int. vol. dm ³	Sur- face m ²	Weight kg	Dimensions mm			
					A	B	C	D
HTC 050 n = 910 rpm								
050.112-...	1 x 22	5	47	43				
050.113-...	1 x 22	7	70	52	1060	830		
050.114-...	1 x 22	9	93	61				
050.122-...	1 x 22	8	93	84				
050.123-...	1 x 28	12	140	101	1860	1630		
050.124-...	1 x 28	16	187	118				
050.132-...	1 x 28	11	140	125				
050.133-...	1 x 35	16	210	150	2660	2430		
050.134-...	1 x 35	22	280	176				
050.143-...	1 x 35	24	280	203				
050.144-...	1 x 42	31	373	237	3460	3230		
HTC 076 n = 930 rpm								
076.112-...	1 x 28	9	102	128				
076.113-...	1 x 28	13	153	146	2000	1340		1x1400
076.114-...	1 x 28	17	204	165				
076.122-...	1 x 35	16	204	253				
076.123-...	1 x 42	24	306	290	3400	2740		2x1400
076.124-...	1 x 42	31	408	326				
076.132-...	1 x 42	25	306	381				
076.133-...	1 x 54	36	459	436	4800	4140		3x1400
076.134-...	1 x 54	49	612	492				
076.142-...	1 x 54	32	408	506				
076.143-...	1 x 54	48	612	580	6200	5540	2740	4x1400
076.144-...	1 x 67	63	817	653				
076.152-...	1 x 54	39	510	632				
076.153-...	1 x 67	58	766	723	7600	6940	4140	5x1400
076.154-...	1 x 67	77	1021	814				
076.162-...	1 x 67	46	612	757				
076.163-...	1 x 67	69	919	866	9000	8340	4140	6x1400
076.164-...	1 x 67	91	1225	974				
HTC 090 n = 850 / 610 rpm								
090.112-...	1 x 28	10	122	230				
090.113-...	1 x 35	16	184	253	2000	1340		1x1400
090.114-...	1 x 35	21	245	275				
090.122-...	1 x 42	19	245	458				
090.123-...	1 x 54	28	367	501	3400	2740		2x1400
090.124-...	1 x 54	38	490	545				
090.132-...	1 x 54	30	367	688				
090.133-...	1 x 67	44	551	755	4800	4140		3x1400
090.134-...	1 x 67	59	735	821				
090.142-...	1 x 67	38	490	916				
090.143-...	1 x 80	57	735	1003	6200	5540	2740	4x1400
090.144-...	1 x 80	76	980	1091				
090.152-...	1 x 67	46	612	1143				
090.153-...	1 x 80	70	919	1252	7600	6940	4140	5x1400
090.154-...	1 x 80	93	1226	1361				

Technical Data HTC 1..

Type HTC	Refrigerant conn. mm	Int. vol. dm ³	Sur- face m ²	Weight kg	Dimensions mm			
					A	B	C	D
HTC 091 n = 850 / 610 rpm								
091.112-...	1 x 35	13	152	251				
091.113-...	1 x 42	19	228	279	2350	1690		1x1750
091.114-...	1 x 42	25	304	307				
091.122-...	1 x 54	25	304	502				
091.123-...	1 x 54	38	457	558	4100	3440		2x1750
091.124-...	1 x 54	51	607	614				
091.132-...	1 x 67	36	455	750				
091.133-...	1 x 67	54	685	832	5850	5190		3x1750
091.134-...	1 x 80	72	911	915				
091.142-...	1 x 67	46	607	998				
091.143-...	1 x 80	70	913	1107	7600	6940	3440	4x1750
091.144-...	1 x 80	93	1214	1216				
091.152-...	1 x 80	57	759	1246				
091.153-...	1 x 80	86	1142	1382	9350	8690	5190	5x1750
091.154-...	1 x 80	114	1518	1518				
HTC 100 n = 670 / 520 rpm								
100.112-...	1 x 35	13	152	251				
100.113-...	1 x 35	19	228	279	2350	1690		1x1750
100.114-...	1 x 42	25	304	307				
100.122-...	1 x 42	25	304	502				
100.123-...	1 x 54	38	457	558	4100	3440		2x1750
100.124-...	1 x 54	51	607	614				
100.132-...	1 x 54	36	455	750				
100.133-...	1 x 67	54	685	832	5850	5190		3x1750
100.134-...	1 x 67	72	911	915				
100.142-...	1 x 67	46	607	998				
100.143-...	1 x 67	70	913	1107	7600	6940	3440	4x1750
100.144-...	1 x 80	93	1214	1216				
100.152-...	1 x 67	57	759	1246				
100.153-...	1 x 80	86	1142	1382	9350	8690	5190	5x1750
100.154-...	1 x 80	114	1518	1518				
HTC 100 n = 420 / 310 rpm								
100.112-...	1 x 35	13	152	251				
100.113-...	1 x 35	19	228	279	2350	1690		1x1750
100.114-...	1 x 35	25	304	307				
100.122-...	1 x 42	25	304	502				
100.123-...	1 x 54	38	457	558	4100	3440		2x1750
100.124-...	1 x 54	51	607	614				
100.132-...	1 x 54	36	455	750				
100.133-...	1 x 54	54	685	832	5850	5190		3x1750
100.134-...	1 x 54	72	911	915				
100.142-...	1 x 54	46	607	998				
100.143-...	1 x 67	70	913	1107	7600	6940	3440	4x1750
100.144-...	1 x 67	93	1214	1216				
100.152-...	1 x 67	57	759	1246				
100.153-...	1 x 67	86	1142	1382	9350	8690	5190	5x1750
100.154-...	1 x 80	114	1518	1518				

Air Cooled Condensers

HTC

HTC 050 . 1•• Horizontal Air Direction

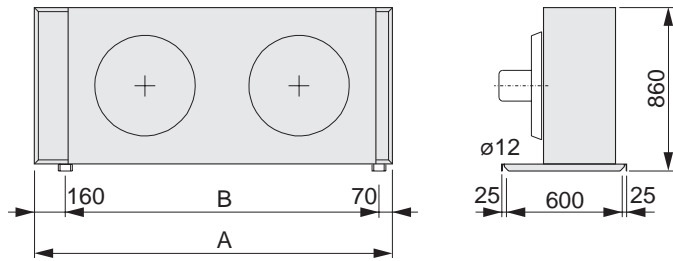

HTC 050 . 1•• Vertical Air Direction

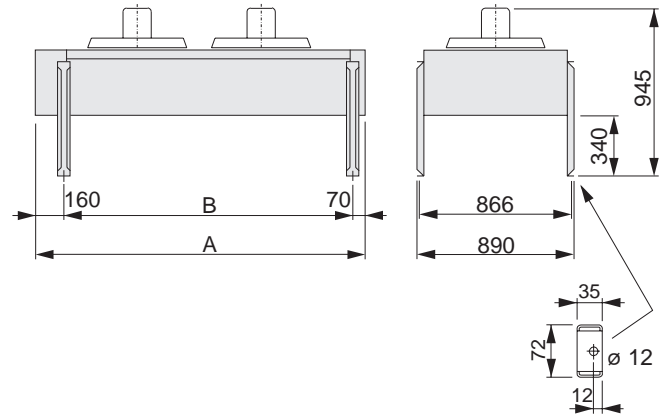

HTC 076 . 1••

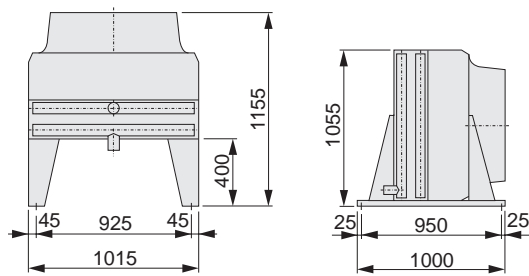

HTC 076 / 090 / 091 / 100 . 1•• Vertical Air Direction

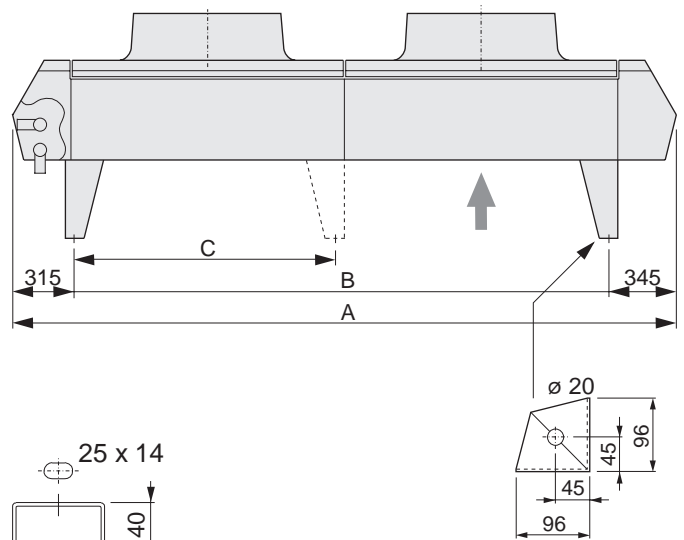

HTC 090 / 091 . 1••

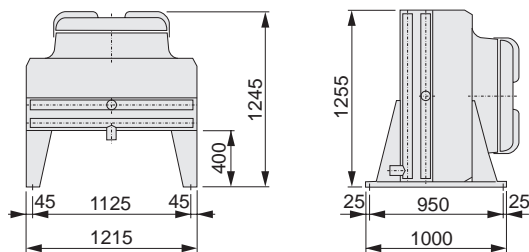

HTC 076 / 090 / 091 / 100 . 1•• Horizontal Air Direction

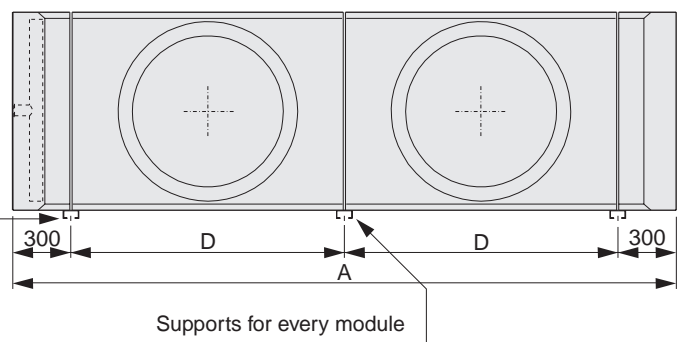

HTC 100 . 1••

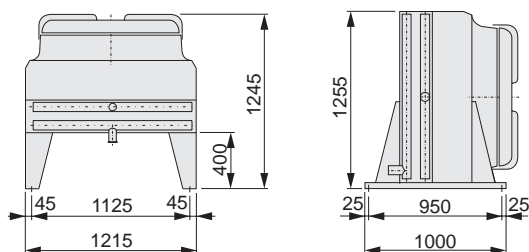

Air Cooled Condensers

HTC

Fan types

All fan types have corrosion resistant fan blades and fan guards.

HTC Type 050

Fans ø 508 mm, complete with protection guards and anti vibration mountings.

Standard execution with fan motors type 050.910.

Terminal boxes are provided with 2 cable inlets M20 x 1.5.

HTC Type 076

Fans ø 762 mm mounted on a motor support.

Fan guards are integrated in the fan plate.

Standard execution with fan motors type 076.930.

Motors are wired to one or more common terminal boxes. The terminal boxes are located on the endplate at the liquid header end of the coil.

HTC Type 090 / 091

Fans ø 900 mm, fan motors integrated with guards and mounted to fan discharge hood.

HTC Type 100

Similar in construction to type 090 / 091, fan diameter however 1000 mm.

All fan motors of HTC models **090**, **091** and **100** are equipped with an overload protector built in the windings. Via terminals in the terminal box this internal protector **must** be used in the control current circuit. The electrical control should be arranged in such a way that continuous on/off switching of the motors ('tripping') is prevented.

When the condensers are out of use for longer periods, the motors have to be switched on for at least 2 hours every month.

HTC Type 050 - 100

For application at ambient temperatures above 40 °C : special motors on request.

Fan motors

Motor type	Number of poles	rpm	Capacity		Motor voltage Volt	Thermal overload relay settings (A) * 230 / 400
			nominal Watt	absorbed Watt		

HTC type 050 (enclosed design, IP-55)

050 . 910	6	910	180	350	230/400/50/3	1.49 / 0.86
050 . 690	8	690	120	250	230/400/50/3	1.16 / 0.67
050 . 470	12	470	25	100	230/400/50/3	0.55 / 0.32
050 . 1420	4	1420	370	600	230/400/50/3	2.42 / 1.40
050 . VAR	6	var.	180	350	230/50/1	2.36 **

HTC type 076 (enclosed design, IP-55)

076 . 930	6	930	750	1170	230/400/50/3	5.0 / 2.9	
076 . 690	8	690	370	560	230/400/50/3	2.6 / 1.5	
076 . 325	16	325	120	290	230/400/50/3	2.0 / 1.2	
076 . 425	YI	6	935	750	1420	400/50/3	3.1
	YII	12	425	150	300	400/50/3	1.1
076 . 930	M	6	930	750	1170	230/50/1	8.0
076 . VAR		6	var.	750	1000	230/50/1	8.4 **
076 . 840		8	840	660	770	230-254/400-440/60/3	4.8 / 2.8

HTC type 090 (enclosed design, IP-54)

090 . 850	Δ	-	850	3300	400/50/3	6.93
	Y	-	610	1900	400/50/3	3.85
090 . 680	Δ	-	680	1750	400/50/3	3.96
	Y	-	520	1200	400/50/3	2.53
090 . 860	Δ	-	830	1600	400/50/3	3.85
	Y	-	610	910	400/50/3	1.98

HTC type 091 (enclosed design, IP-54)

091 . 850	Δ	-	850	3300	400/50/3	6.93
	Y	-	610	1900	400/50/3	3.85
091 . 680	Δ	-	680	1750	400/50/3	3.96
	Y	-	520	1200	400/50/3	2.53
091 . 860	Δ	-	830	1600	400/50/3	3.85
	Y	-	610	910	400/50/3	1.98

HTC type 100 (enclosed design, IP-54)

100 . 670	Δ	-	650	2200	400/50/3	4.6
	Y	-	460	1350	400/50/3	3.0
100 . 420	Δ	-	420	860	400/50/3	2.2
	Y	-	310	500	400/50/3	1.07
100 . 380	Δ	-	380	670	400/50/3	1.54
	Y	-	250	330	400/50/3	0.74

* The settings can be applied to a minimum ambient temperature of -10 °C

** Value at highest speed.

Note : Actual fan speed may differ from the values as indicated on the motor name plate.

Air Cooled Condensers

HTC

Factors for calculation of the condenser capacity

The condenser capacity is the compressor capacity multiplied with the factor from the diagram. The diagrams are valid for R 404A. At evaporating temperatures below -20 °C the condenser capacity has to be calculated from the compressor capacity at -20 °C, or a starting control should be used to protect the compressors from high starting loads.

OPEN compressors

SEMI-HERMETIC compressors
(motor air/water cooled)

Factor

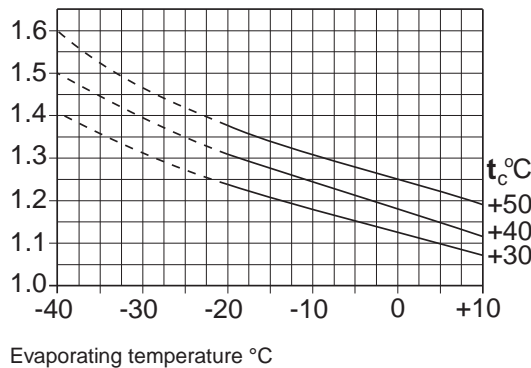

SEMI-HERMETIC compressors
(motor suctiongas cooled)

HERMETIC compressors

Factor

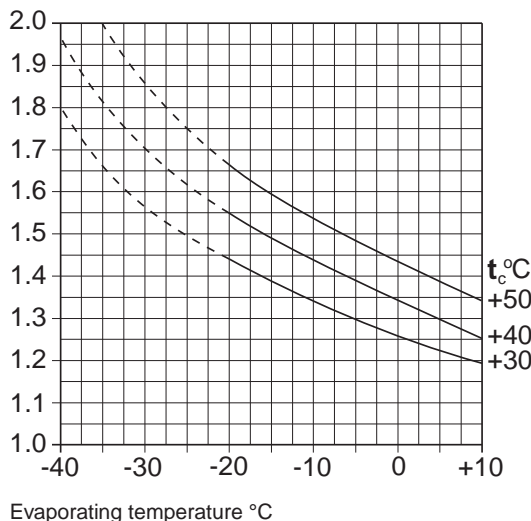

Capacity

The basic capacity ratings (pages 4, 5 and 8, 9) are for R404A at a t_d * of 15 K and ambient temperatures up to 25 °C.

* t_d = difference between condensing- and ambient temperature.

Capacities are directly proportional with other temperature differences between 10 and 20 K.

The refrigerant circuiting is optimised to the selected fan speed. When selecting a condenser model with two fan speeds a 'first choice' fan speed has to be given to which the refrigerant circuiting will be designed. The condenser capacity for the 'second choice' fan speed can be up to 10 % below the stated capacity.

Correction factors

		Factor
Refrigerant	R 404A, R 507	1.00
	R 134a	0.93
	R 407C	0.87
	R 22	0.96
Ambient temperature :	25 °C	1.00
	35 °C	0.96
	40 °C	0.94
	50 °C	0.91
(special motor)		
Altitude above sea level :	0 m	1.00
	500 m	0.97
	1000 m	0.93
	1500 m	0.90
	2000 m	0.86
	2500 m	0.83
Application of motors suitable for 60 Hz with n = 840 rpm		0.95

Example : HTC 076 . 124 - 60 Hz fans

What is the condenser capacity at an ambient temperature of 40 °C, refrigerant R404A, altitude at sea level and equipped with motors for 60 Hz ?

Nominal capacity at 15 K tv : 110.7 kW
 Correction factors : t = 40 °C : 0.94
 altitude sea level : 1.00
 60 Hz motors : 0.95

Corrected capacity :
 0.94 x 1.00 x 0.95 x 110.7 = 98.9 kW

Capacity control

For multifan models capacity can be controlled by cycling one or more fans. Capacity control on all models is also possible by using 2-speed or speed regulated single phase motors (in combination with an electronic speed control device).

The fan compartments are separated by baffle plates.

Air Cooled Condensers

HTC

Multi circuiting

Condensers can be supplied (at extra cost) with multi circuiting.

Soundlevels dB(A)

The soundlevels in the tables on pages 4, 5, 8 and 9 are the results of tests in free field conditions.

The values are measured in the horizontal plane at a distance of 10 m. More information on request.

The table below gives sound level corrections at various distances.

Distance m	Correction dB(A)
1	+ 20
2	+ 14
3	+ 10
4	+ 8
5	+ 6
10	0
20	- 6
50	- 14
100	- 20

Extended feet

Extended feet can be supplied as optional extra for condenser models 076, 090, 091 and 100. These feet are supplied separately. The standard feet height gives 400 mm free space under the condenser. Extended feet are available for heights of 600 mm.

Transport

All models are provided with lifting lugs. To avoid damage during hoisting, a hoisting beam should be used, by which the given angles are to be considered. Beware of shocks during transport and handling (sudden lifting).

Mounting

Refrigerant pipework connections are to be soldered free of tension.

When connecting more than one condenser in parallel the pressure drop on the refrigerant side has to be considered.

Location

Air movement

Condensers should be positioned to achieve the following criteria :

- Adequate space (min. 1.0 metre) must be left for free entry to the coil inlet face.
- No restrictions to the air discharge.
- No possibility of direct air recirculation (short circuiting of air).

Installation and maintenance

For more information on installation and maintenance of air cooled condensers model HTC we refer to our brochure nr. 88.02 ("Installation and Maintenance Instructions for Aircooled Condensers").

This brochure is issued with every condenser.

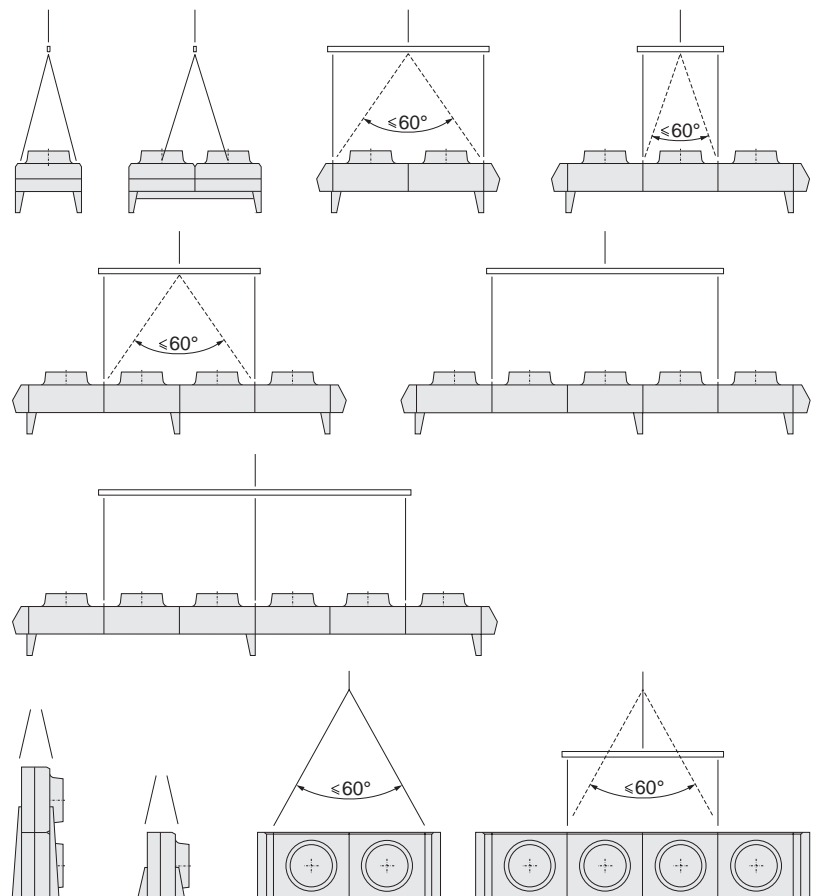



HELPMAN

Helpman BV
Postbus 44
9700 AA Groningen
Tel. 050-5217555
Fax 050-5264878
E-mail info@helpman.com
Internet www.helpman.com